

INFORMATION SHEET

T 8350 EN

Information Sheet of Valve Accessories

Positioners · Limit Switches · Solenoid Valves · Valve Accessories



Selection and application

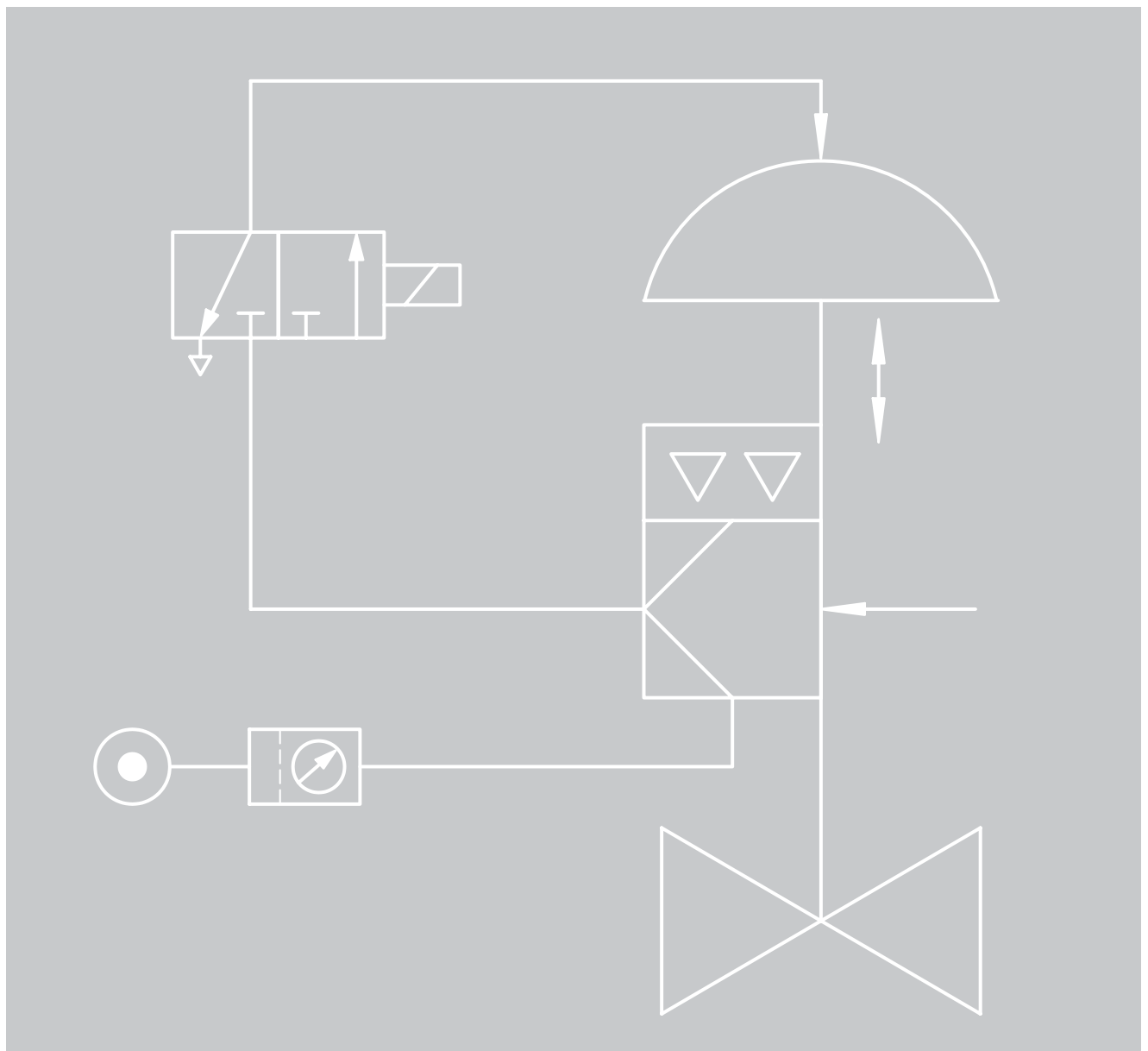

Overview

This Information Sheet contains information on transfer devices for pneumatic control valves and on devices for supplying pneumatic control instruments with compressed air. It outlines the features and main technical data of these devices.

The following groups of devices are described:

Digital and analog positioners (see Chapter 1)

Positioners ensure a predetermined assignment of the valve position to the control signal and supply a corresponding output signal pressure.

Limit switches (see Chapter 2 from page 11)

Limit switches consist of two inductive, electric or pneumatic contacts. They issue a signal whenever an adjusted limit is exceeded or not reached.

Solenoid valves (see Chapter 3 on page 14)

Solenoid valves convert binary signals issued by electric control equipment into binary pneumatic control signals.

Accessories (see Chapter 4 from page 16)

- Pneumatic lock-up valve
- Remote adjuster
- Supply pressure regulator
- Filter regulator
- Service units
- Reversing amplifier
- Volume booster
- Quick exhaust valve

1 Positioners

Principle of operation

Positioners ensure a predetermined assignment of the valve position (controlled variable x) to the input signal (reference variable w). They compare the control signal issued by pneumatic or electric automation equipment (controller, control station, process control system) to the position or opening angle of the control valve and supply a corresponding output signal pressure (p_{st} , output variable y). Positioners are often used as servo-booster as they convert low-energy signals into strong proportional signal pressures up to the maximum supply pressure (6 bar/90 psi). They can be used in standard and split-range operation.

Pneumatic and electropneumatic positioners

Depending on the input signal, a distinction is made between pneumatic (p/p) and electropneumatic (i/p) positioners:

- **Pneumatic (p/p) positioners:**
Pneumatic positioners accept an input signal of 0.2 to 1 bar (3 to 15 psi) and issue an output signal pressure (p_{st}) of maximum 6 bar (90 psi).
- **Electropneumatic (i/p) positioners:**
Electropneumatic positioners use an analog DC signal of 0/4 to 20 mA or 1 to 5 mA as the input variable and issue an output signal pressure (p_{st}) up to 6 bar (90 psi).

Digital positioners

SAMSON digital positioners are single-acting or double-acting positioners for attachment to pneumatic linear or rotary actuators.

Due to their digital signal processing technology, these positioners have the following advantages over conventional positioners:

- Easy operation
- LCD with rotatable reading direction
- Automatic zero and span calibration during initialization (except for Type 3730-0)
- Automatic detection of faults in the actuator
- Direction of action independent of mounting position
- Continuous zero monitoring
- Low air consumption
- All parameters saved in non-volatile EEPROM

Digital positioners can be fitted with additional functions:

- Inductive limit contacts
- Solenoid valve
- Position transmitter
- External position sensor
- Analog input
- Binary input and output
- Forced venting
- Leakage sensor

Communication

The positioners also allow HART® communication between the field and process control level.

- TROVIS 3730-3
- TROVIS 3793
- Type 3730-3
- Type 3730-6
- Type 3731-3

Further protocols supported by SAMSON positioners:

PROFIBUS® PA: Type 3730-4

FOUNDATION™ fieldbus: Type 3730-5, Type 3731-5

Modular designed positioners with high air capacity

The Series 3793 Positioners expand the range of functions that Series 3730 Positioners have to offer. They have a modular design and generate a high air capacity. Variable outputs, e.g. double-acting control, can be achieved by using exchangeable pneumatic modules that can be retrofitted. Optional additional functions, such as limit contacts, position feedback or binary inputs and outputs, can be added to the positioner on site as option modules.

Other features:

- Non-contact position sensing
- Plain-text display with NAMUR Recommendation NE 107 status messages on the device
- Simple one-knob, menu-driven operation
- Pressure sensors
- Integrated EXPERTplus valve diagnostics
- Simple attachment to all common linear and rotary actuators
- **TROVIS 3793:**
Single-acting or double-acting positioners with HART® communication

Digital positioners for on/off valves in safety-instrumented systems

TROVIS SAFE

TROVIS SAFE digital positioners with single-acting or double-acting function are SIL-certified devices for attachment to pneumatic control valves in safety-instrumented systems. In addition to the integrated valve diagnostics, they perform full stroke tests (FST) and partial stroke tests (PST) and contain ready-configured parameters for on/off valves and HART® communication.

- **TROVIS SAFE 3730-6:**
Positioner same as Type 3730-6 with special use for control of on/off valves in safety-instrumented systems
- **TROVIS SAFE 3731-3:**
Flameproof positioner same as Type 3731-3 with special use for control of on/off valves in safety-instrumented systems
- **TROVIS SAFE 3793:**
Single-acting or double-acting positioner, modular design with high air capacity, with HART® communication for attachment to pneumatic on/off valves in safety-instrumented systems

Table 1: Pneumatic or electropneumatic positioners · Technical data and features

Type	4765	4763	3766	3767
Input/output signal	p/p	i/p	p/p	i/p
Rated travel	7.5 to 90 mm	7.5 to 90 mm	7.5 to 120 mm	7.5 to 120 mm
For linear actuators acc. to IEC 60534-6-1	•	•	•	•
For Type 3277 (direct attachment)	–	–	•	•
For linear actuators with rod-type yoke	•	•	•	•
For Type 3278 Rotary Actuator	–	–	•	•
For rotary actuators according to VDI/ VDE 3845	–	–	•	•
Opening angle	–	–	Up to 90°	Up to 90°
Set point	0.2 to 1 bar	•	–	–
	0/4 to 20 mA	–	•	•
	1 to 5 mA	–	•	•
Supply air	1.4 to 6 bar (20 to 90 psi)	1.4 to 6 bar (20 to 90 psi)	1.4 to 6 bar (20 to 90 psi)	1.4 to 6 bar (20 to 90 psi)
Signal pressure output (max.)	0 to 6 bar (0 to 90 psi)	0 to 6 bar (0 to 90 psi)	0 to 6 bar (0 to 90 psi)	0 to 6 bar (0 to 90 psi)
Characteristic	Linear	Linear	Linear	Linear
Permissible ambient temperature	-20 to +80 °C	-20 to +70 °C 3)	-20 to +80 °C	-20 to +80 °C
	Extended temperature range down to -40 °C on request			
Can be converted to p/p or i/p positioner	•	•	•	•
Degree of protection	IP54/IP65		IP54/IP65/NEMA 4X	
Conformity		CE	CE · EAC	CE · EAC
Explosion protection (further approvals according to national and international guidelines listed in data sheet)				
ATEX Ex i	–	•	•	•
ATEX Ex d	• 1)	• 2)	• 1)	• 2)
FM/CSA	–	•	•	•
Options				
Limit contact	–	–	2 (inductive)	2 (inductive)
Solenoid valve	–	–	•	•
Position transmitter	–	–	• 4)	• 4)
Pressure gauges	•	•	–	–
Data sheets	▶ T 8359	▶ T 8359	▶ T 8355	▶ T 8355

1) Flameproof enclosure in combination with Type 6116 i/p Converter

2) Flameproof enclosure in combination with Type 3770 Field Barrier

3) Maximum temperature range depending on which i/p converter is used ▶ T 8359

4) Available until March 2011

Analog positioners



Fig. 1: Type 3730-0 Electropneumatic Positioner



Fig. 2: Type 3766 Pneumatic Positioner



Fig. 3: Type 4763/4765 Electropneumatic Positioner

Examples of attachment



Fig. 4: Type 3730 Positioner Attachment to NAMUR rib



Fig. 5: Type 3767 Positioner Attachment to Type 3278 Rotary Actuator



Fig. 6: Type 4765/6116 Positioner Attachment to NAMUR rib

Table 2: Electropneumatic positioners · Technical data and features

Positioner	TROVIS 3730-1	TROVIS 3730-3	TROVIS 3793	Type 3725	Type 3730-0	Type 3730-1	
Rated travel mm	3.5 to 300	3.6 to 300	3.6 to 300	3.75 to 50	5.3 to 200	3.75 to 200	
Opening angle	24 to 100°	24 to 100°	24 to 170°	24 to 100°	–	24 to 100°	
Set point	4 to 20 mA	4 to 20 mA	4 to 20 mA	4 to 20 mA	4 to 20 mA	4 to 20 mA	
Supply air	1.4 to 7 bar (20 to 105 psi)	1.4 to 7 bar (20 to 105 psi)	2.5 to 10 bar 30 to 150 psi	1.4 to 7 bar (20 to 105 psi)	1.4 to 7 bar (20 to 105 psi)	1.4 to 7 bar (20 to 105 psi)	
Signal pressure output (max.)	0 to 7 bar (0 to 105 psi)	0 to 7 bar (0 to 105 psi)	0 to 10 bar 0 to 150 psi	0 to 7 bar (0 to 105 psi)	0 to 7 bar (0 to 105 psi)	0 to 7 bar (0 to 105 psi)	
Characteristic	Adjustable	Adjustable	Adjustable	Adjustable	Linear	Adjustable	
Permissible ambient temperature	-55 to +85 °C	-55 to +85 °C	-55 to +85 °C	-25 to +80 °C	-45 to +80 °C	-45 to +80 °C	
Degree of protection	IP66/NEMA 4X	IP66/NEMA 4X	IP66	IP66	IP66/NEMA 4X	IP66/NEMA 4X	
Conformity	CE · EAC	CE · EAC	CE · EAC	CE · EAC	CE	CE	
Communication	–	HART®	HART®	–	–	–	
Diagnostics	–	EXPERTplus	EXPERTplus	–	–	–	
Operation using TROVIS-VIEW	•	•	•	–	–	–	
Explosion protection (further approvals according to national and international guidelines listed in data sheet)							
ATEX Ex i	•	•	•	•	•	•	
ATEX Ex d	–	–	–	–	• 1)	• 1)	
IECEX	•	•	•	–	–	•	
FM	–	–	•	–	•	•	
CSA	–	–	–	•	•	•	
Additional electrical equipment							
Limit contact	•	•	•	–	–	•	
Position transmitter	•	•	•	–	–	–	
Solenoid valve	–	–	–	–	–	–	
Forced venting	–	•	•	–	–	–	
External position sensor	–	•	–	–	–	–	
Analog input	–	–	–	–	–	–	
Binary input	–	•	•	–	–	–	
Binary output	–	•	•	–	–	–	
Leakage sensor	–	–	–	–	–	–	
Data sheets	▶ T 8484-1	▶ T 8484-3	▶ T 8493	▶ T 8394	▶ T 8384-0	▶ T 8384-1	

1) Flameproof enclosure in combination with Type 3770 Field Barrier



Fig. 7: TROVIS 3793



Fig. 8: TROVIS 3730-3

	Type 3730-2	Type 3730-3	Type 3730-4	Type 3730-5	Type 3730-6	Type 3731-3	Type 3731-5
	3.6 to 300	3.6 to 300	3.6 to 300	3.6 to 300	3.6 to 300	3.6 to 200	3.6 to 200
	24 to 100°	24 to 100°	24 to 100°	24 to 100°	24 to 100°	24 to 100°	24 to 100°
	4 to 20 mA	4 to 20 mA	15 mA	15 mA	4 to 20 mA	4 to 20 mA	15 mA
	1.4 to 7 bar (20 to 105 psi)	1.4 to 7 bar 20 to 105 psi	1.4 to 7 bar 20 to 105 psi	1.4 to 7 bar 20 to 105 psi	1.4 to 7 bar 20 to 105 psi	1.4 to 6 bar 20 to 90 psi	1.4 to 6 bar 20 to 90 psi
	0 to 7 bar (0 to 105 psi)	0 to 7 bar 0 to 105 psi	0 to 7 bar 0 to 105 psi	0 to 7 bar 0 to 105 psi	0 to 7 bar 0 to 105 psi	0 to 6 bar 0 to 90 psi	0 to 6 bar 0 to 90 psi
	Adjustable	Adjustable	Adjustable	Adjustable	Adjustable	Adjustable	Adjustable
	-45 to +80 °C	-45 to +80 °C	-45 to +80 °C	-45 to +80 °C	-45 to +80 °C	-40 to +80 °C	-40 to +80 °C
	IP66/NEMA 4X	IP66/NEMA 4X	IP66/NEMA 4X	IP66/NEMA 4X	IP66/NEMA 4X	IP66/NEMA 4X	IP66/NEMA 4X
	CE	CE	CE · EAC	CE · EAC	CE	CE · EAC	CE
	–	HART®	PROFIBUS	FOUNDATION™ fieldbus	HART®	HART®	FOUNDATION™ fieldbus
	EXPERTplus	EXPERTplus	EXPERTplus	EXPERTplus	EXPERTplus	EXPERTplus	EXPERTplus
	•	•	•	•	•	•	•
	•	•	•	•	•	–	–
	• 1)	• 1)	–	–	• 1)	•	•
	•	•	•	•	•	•	•
	•	•	•	•	•	–	–
	•	•	•	•	•	–	–
	–	•	–	–	–	–	–
	•	•	•	•	•	•	•
	–	–	–	–	–	–	–
	•	•	–	•	•	–	–
	▶ T 8384-2	▶ T 8384-3	▶ T 8384-4	▶ T 8384-5	▶ T 8384-6	▶ T 8387-3	▶ T 8387-5



Fig. 9: TROVIS 3730-x/Type 3730-x

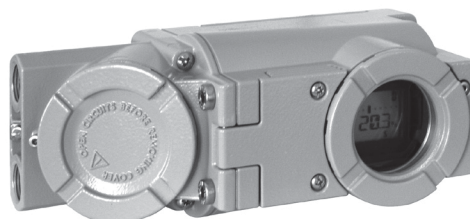

Fig. 10: Type 3731-x



Fig. 11: Type 3725

Table 3: Digital positioners for on/off valves in safety-instrumented systems · Technical data and features

TROVIS SAFE	3730-6	3731-3	3793
Rated travel	3.6 to 300 mm	3.6 to 200 mm	3.6 to 300 mm
Opening angle	24 to 100°	24 to 100°	24 to 170°
Set point	4 to 20 mA	4 to 20 mA	4 to 20 mA
Communication	HART®	HART®	HART®
Supply air	1.4 to 7 bar (20 to 105 psi)	6 bar (105 psi)	2.5 to 10 bar (30 to 150 psi)
Signal pressure output (max.)	7 bar (105 psi)	6 bar (105 psi)	10 bar (150 psi)
Characteristic	Adjustable	Adjustable	Adjustable
Ambient temperature	-45 to +80 °C	-45 to +80 °C	-55 to +85 °C
Degree of protection	IP66	IP66	IP66
Conformity	CE	CE	CE · ENEC
Certification according to IEC 61508/SIL ¹⁾	•	•	–
Operation using TROVIS-VIEW	•	•	•
Diagnostics	EXPERTplus	EXPERTplus	EXPERTplus
Partial stroke testing	•	•	•
Explosion protection (further approvals according to national and international guidelines listed in data sheet)			
ATEX Ex i	•	–	•
ATEX Ex d	• ²⁾	•	–
IECEX	•	•	•
FM	•	•	•
CSA	•	•	–
Additional electrical equipment			
Limit contact	•	–	•
Position transmitter	•	•	•
Solenoid valve	•	–	–
Forced venting	•	•	•
External position sensor	•	–	–
Analog input	–	–	•
Binary input	•	•	•
Binary output	–	–	•
Leakage sensor	•	–	–
Data sheets	▶ T 8384-6S	▶ T 8387-3S	▶ T 8493S

¹⁾ Suitable for use in safety-instrumented systems according to IEC 61511 up to SIL 2 (single device/HFT = 0) and SIL 3 (redundant configuration/HFT = 1)

²⁾ Flameproof enclosure in combination with Type 3770 Field Barrier

Digital positioners for on/off valves in safety-instrumented systems



Fig. 12: TROVIS SAFE 37393



Fig. 13: TROVIS SAFE 3730-6



Fig. 14: TROVIS SAFE 3731-3

Examples of attachment



Fig. 15: Type 3725, NAMUR attachment to Type 3241 Valve



Fig. 16: TROVIS 3793, attachment to Type 3241 Valve



Fig. 17: TROVIS 3730-1, direct attachment to Type 3277 Actuator:

TROVIS-VIEW software

Universal configuration and user interface for various smart SAMSON instruments, such as positioners, industrial and heating controllers, electric actuators, electric actuators with process controller and differential pressure meters.

- Easy operation
- Selectable language
- Modular structure with user interface, communications server and device-specific database modules containing characteristic properties, e.g. parameters, data points, user levels etc.
- This means that data can be changed in the device immediately or they can be saved on the computer first and downloaded to the device on site.
- Direct operation and monitoring in online operation · In addition to cyclical refreshment of data points, freely definable data points can also be logged. Data can be viewed both as a graph and in tables. Data can be imported and exported.
- Communication can be operated over a network

See data sheet for further details ▶ T 6661.

The TROVIS-VIEW software is available for downloading free of charge from our website (www.samsongroup.com > Downloads > Software & Drivers> TROVIS-VIEW).

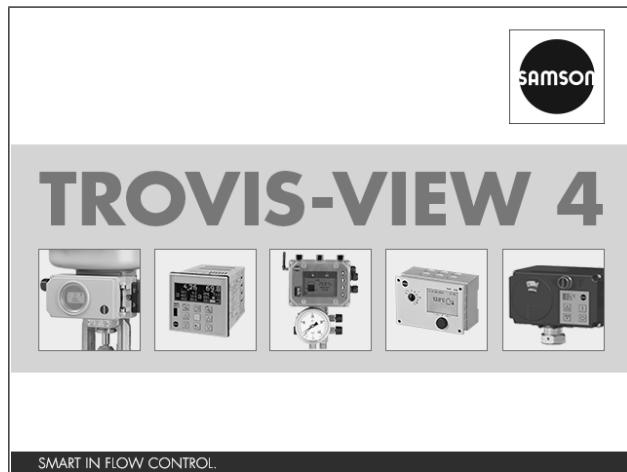

EXPERTplus valve diagnostics for positioners

EXPERTplus is a firmware extension for Series 3730, 3731 and 3793 Positioners for early recognition of valve faults, issuing recommended action for predictive maintenance.

The full scope of diagnostic functions is completely integrated into the positioner. EXPERTplus is integrated into the TROVIS-VIEW software, allowing users to access, read and edit the diagnosis and is easy to learn.

EXPERTplus supports FDT/DTM and EDD.

Further information:

Types 3730-2/-3/-4/-5 Positioners	▶ T 8389
Type 3731-3 Positioner	▶ T 8389
TROVIS SAFE 3731-3 Positioner	▶ T 8389S
Type 3730-6 Positioner	▶ T 8389-1
TROVIS SAFE 3730-6 Positioner	▶ T 8389-1S
TROVIS 3793 Positioner	▶ T 8389-2
TROVIS SAFE 3793 Positioner	▶ T 8389-2S
TROVIS 3730-3 Positioner	▶ T 8389-3

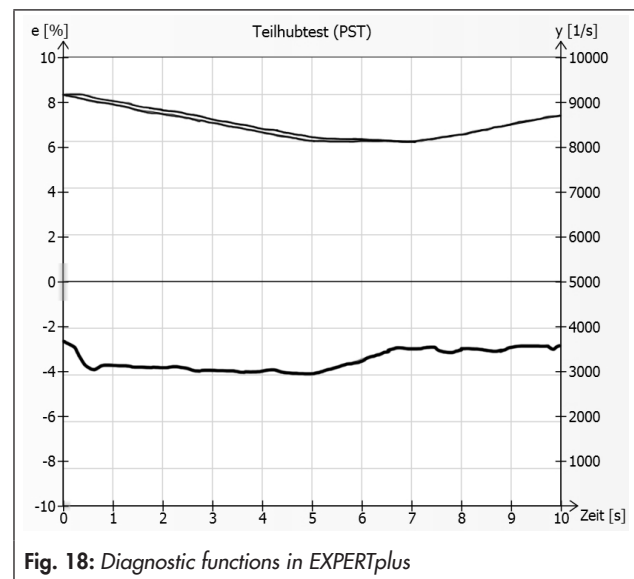

Fig. 18: Diagnostic functions in EXPERTplus

2 Limit switches

Limit switches are suitable for automation of on/off applications and issue an electric binary signal when the valve travel exceeds or falls below an adjusted limit. The signal can be used, for example for switching control signals, issuing visual and audible alarms or for connection to central control or alarm systems.

The installed limit contacts are either:

- Inductive
- Software-based
- Electric
- Pneumatic

The contacts, which can be overridden for the most part, can be used either as normally open contacts or normally closed contacts. Depending on the version, the limit switch can contain up to six limit contacts.

The limit switches can be attached to linear or rotary actuators or directly to pneumatic or electropneumatic positioners depending on the control valve assembly. The limit switch is linked axially over the shaft in rotary actuators or linked using a lever in linear actuators.

An optional solenoid valve allows the monitored actuator also to be controlled.

Limit switches for on/off valves in safety-instrumented systems

The Type 3776 Limit Switch can execute the safety-instrumented function by performing the safety-related end position monitoring and emergency venting. An optionally integrated solenoid valve can be used for emergency venting. In this case, the limit switch discharges its pneumatic output to the atmosphere when the solenoid valve is de-energized, causing the mounted actuator to be vented.

The function is suitable for use in safety-instrumented systems. The Type 3776 can be used up to SIL 2 (single device) and SIL 3 (redundant configuration) observing the requirements of IEC 61511 and the required hardware fault tolerance.

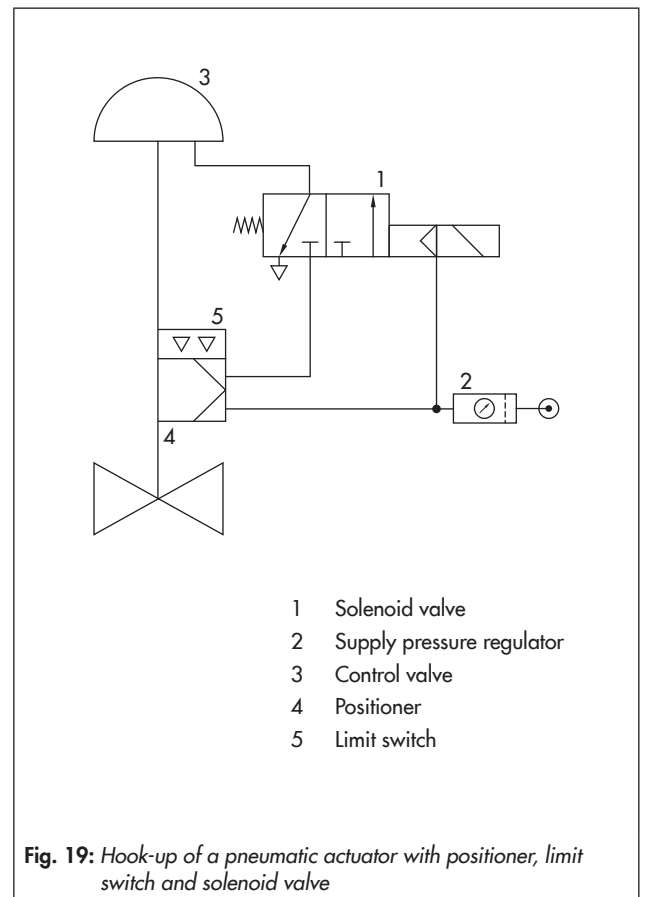

Table 4: Limit switches without solenoid valve

Type	4746	4744	4747
Rated travel	7.5 to 180 mm	7.5 to 150 mm	7.5 to 200 mm
Opening angle	–	–	0 to 100°
Limit contacts	Inductive	•	•
	Electric	•	•
	Pneumatic	•	
Safety-instrumented function (SIL)	• 1)		
Conformity	CE · EAC	CE	CE · EAC
Explosion protection (further approvals according to national and international guidelines listed in data sheet)			
ATEX Ex i	•		•
ATEX Ex d		•	•
ATEX Ex n	•		•
IECEX			•
FM	•		•
CSA	•		•
Data sheets	▶ T 8365	▶ T 8367	▶ T 4747

1) Applies to the proximity switches used in the inductive version as stated in manufacturer's declaration HE 1088

Table 5: Limit switches with optional solenoid valve

Type	3768	3738-20	3738-50	3776	4740
Rated travel	7.5 to 120 mm	7.5 to 300 mm	7.5 to 300 mm	7.5 to 200 mm	0 to 15 mm
Opening angle	0 to 90°	0 to 30/170°	0 to 30/170°	0 to 100/180°	–
Limit contacts	Inductive	•		•	•
	Electric		•	•	•
Safety-instrumented function (SIL)	• 1)			•	
Conformity	CE	CE	CE	CE · EAC	CE
Communication			FOUNDATION™ fieldbus	AS-Interface module with bus connection	
Explosion protection (further approvals according to national and international guidelines listed in data sheet)					
ATEX Ex i	•	•	•	•	–
ATEX Ex n	•	•	•	•	
FM	•			•	
CSA	•				
Data sheets	▶ T 8356	▶ T 8390	▶ T 8390-5	▶ T 3776	▶ T 8357

1) Applies to the proximity switches used in the inductive version as stated in manufacturer's declaration HE 1088

Limit switch



Fig. 20: Type 4746 Limit Switch · With pneumatic (left) and electric (right) limit contacts

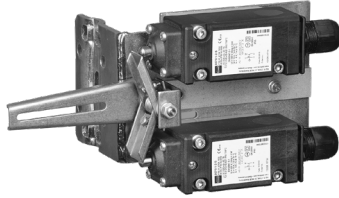

Fig. 21: Type 4744 Limit Switch



Fig. 22: Type 4747 Limit Switch



Fig. 23: Type 3738 Limit Switch



Fig. 24: Type 3768 Limit Switch



Fig. 25: Type 3776 Limit Switch

Examples of attachment



Fig. 26: Type 4747 Limit Switch, attachment to a NAMUR rib

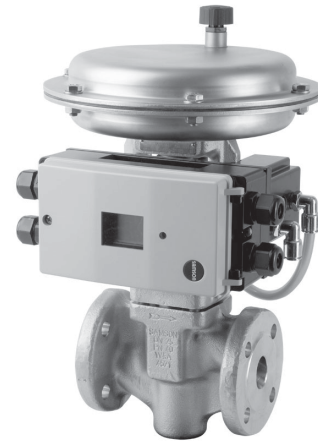

Fig. 27: Type 3738-20 Electronic Limit Switch, attachment to Type 3241-1 Control Valve

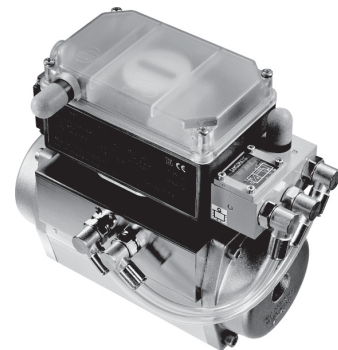

Fig. 28: Type 3776 Limit Switch for rotary actuators according to VDI/VDE 3845

3 Solenoid valves

Solenoid valves convert binary signals issued by electric control equipment into binary pneumatic control signals which close or open the control valve.

The principle of operation is similar to an electropneumatic converter unit (i/p converter) and a valve configuration corresponding with the valve's switching function. Intrinsically safe, low-power binary signals issued by automation equipment or fieldbus systems can be used for controlling purposes.

Depending on the solenoid valve model and version, 3/2-way, 5/2-way, 5/3-way or 6/2-way functions can be implemented. Different types of protection, flow rates, connections as well as SAMSON's modular design of the solenoid valves make it possible to create a wide variety of device versions tailor-made for various tasks.

Table 6: Data and features of solenoid valves ¹⁾

Type	3963	3967	3969	3962	3966	
Switching function	3/2 · 5/2 · 5/3 · 6/2	3/2 · 5/2 · 5/3	3/2	3/2 · 5/2 · 5/3 · 6/2	3/2	
Attachment						
NAMUR interface acc. to VDI/VDE 3845	•	•	•	•	•	
Integral attachment acc. to VDI/VDE 3847	•	•	•		•	
NAMUR ribs acc. to IEC 60534-6-1	•	•	•	• ³⁾	•	
Threaded connections	•	•	•	•	•	
Nominal signal	V DC V AC	6/12/24 115/230	6/12/24 –	14 to 24 –	24/48/115/230 24/48/115/230	6/12/24/115 24/115/230
Permissible pressures						
Supply air	1.4 to 6 bar	1.4 to 10 bar ⁴⁾	1.4 to 10 bar ⁴⁾	1.4 to 10 bar ⁴⁾	1.4 to 6 bar	
Maximum operating pressure	10 bar ⁴⁾	10 bar	10 bar	10 bar	10 bar ⁴⁾	
Compatible with SAMSON's modular design concept ²⁾	Depending on version	Fully compatible	Fully compatible	Depending on version	Fully compatible	
SIL safety-instrumented function	•	•	•	•		
Conformity	CE	CE · EAC	CE	CE	CE	
Explosion protection (further approvals according to national and international guidelines listed in data sheet)						
ATEX Ex i	•	•	•		•	
ATEX Ex d				•	•	
ATEX Ex m				•		
IECEX		•	•	•		
CSA	•				•	
FM	•				•	
EAC	•	•		•		
NEPSI	•	•		•		
Data sheets	▶ T 3963	▶ T 3967	▶ T 3969	▶ T 3962	▶ T 3966	

¹⁾ Further solenoid valves and solenoid valve islands ▶ www.samsongroup.com

²⁾ ▶ SAMSON's modular design concept

³⁾ With adapter plate from ▶ SAMSON's modular design concept

⁴⁾ Depending on the version (see data sheet)

Solenoid valves



Fig. 29: Type 3963 5/2-way Solenoid Valve



Fig. 30: Type 3967 Solenoid Valve with NAMUR interface



Fig. 31: Type 3966 Solenoid Valve



Fig. 32: Type 3969 Solenoid Valve



Fig. 33: Type 3962 Solenoid Valve, Ex d (Ex em)

4 Accessories

4.1 Type 3709 Pneumatic Lock-Up Valve

Pneumatic lock-up valves shut off the signal pressure line of pneumatic actuator either when the air supply falls below an adjusted value or upon complete air supply failure. As a result, the pressure in the actuator is blocked. The actuator remains in its last position until the defect is eliminated.



Fig. 34: Type 3709-1 Pneumatic Lock-up Valve



Fig. 35: Type 3709-4 Pneumatic Lock-up Valve

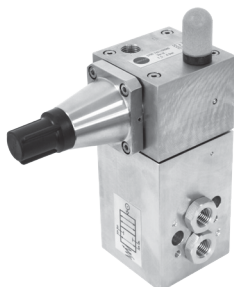

Fig. 36: Type 3709-5 Pneumatic Lock-up Valve



Fig. 37: Type 3709-6 Pneumatic Lock-up Valve

Table 7: Data and features of lock-up valves

Type 3709		-01	-02	-04	-05	-06 ¹⁾	-07	-08 ¹⁾
Supply air in bar	Max.	12	12	6	6	6	6	6
K _{VS} coefficient	Approx.	0.2	0.2	4.3	2.0	4.3	2.0	4.3
Set point range in bar		0.5 to 6	0.5 to 6	1.5 to 6	1.5 to 6	1.5 to 6	1.5 to 6	1.5 to 6
Perm. ambient temperature		-25 to +80 °C		-40 to +80 °C				
Direct attachment to positioner		•						
Hooked up as required			•	•				
Attachment on a solenoid valve							•	•
Attachment according to VDI/VDE 3845 (rotary actuators)					•	•	•	•
Single-acting		•	•	•	•	•	•	•
Double-acting								
With booster				•	•	•	•	•
Connecting thread		G/NPT	G/NPT	G/NPT	G/NPT	G/NPT	G/NPT	G/NPT
Data Sheet		▶ T 8391						

4.2 Type 3759 Pneumatic Remote Adjuster

The remote adjuster is a precision pressure regulator which can be adjusted manually. It is designed for use in pneumatic control loops as either a set point adjuster or manual remote adjuster and can be used as an adjustable precision pressure regulator for measuring, calibration and testing equipment.

Versions

The Type 3759 Pneumatic Remote Adjuster (Fig. 38) is designed for the following pressure ranges:

- 0 to 0.6 bar
- 0 to 1.6 bar
- 0 to 4.0 bar
- 0 to 6.0 bar

The maximum supply pressure for all versions is 7 bar.

Technical data

Output pressure	bar	0 to 0.6	0 to 1.6	0 to 4	0 to 6
Required supply pressure	bar	1.4 to 7	2 to 7	5 to 7	7
Flow rate in l_n/h (max. air supply) with an upstream pressure of (bar)	2	2000			
	5	4000			
	7	5300			
Air consumption in l_n/h in steady state with an upstream pressure of (bar)	2	70			
	5	110			
	7	130			
Data Sheet		▶ T 8510			



Fig. 38: Type 3759 Pneumatic Remote Adjuster

4.3 Type 4708 Supply Pressure Regulator

Supply pressure regulators provide pneumatic control instruments with a constant air supply. The supply pressure regulator reduces and controls the pressure of a compressed air network to the pressure adjusted at the set point adjuster.

Versions are available for installation in pipelines or control panels or for direct attachment to positioners or pneumatic actuators.

The air pressure reducing station consists of a supply pressure regulator and an upstream filter with condensate drain.

Technical data

Type	4708-xx
Set point range	0.5 to 6 bar (8 to 90 psi) or 0.2 to 1.6 bar (3 to 24 psi)
Operating pressure p_1	Max. 12 bar (174 psi)
Version	Aluminum or stainless steel body
Ambient temp. range	Depending on version: -25 to +80 °C (standard), -50 to +80 °C (low-temperature version)
Air filtering	15 to 20 μm mesh size (5 μm as special version)
Options	Pressure gauge, manual/automatic switchover for positioners
Data Sheet	▶ T 8546

Version for increased air capacity: **Type 4708-45** (Fig. 40)



Fig. 39: Type 4708-53 (left) and Type 4708-12 (right) Supply Pressure Regulator

Fig. 40: Type 4708-45 Supply Pressure Regulator for increased air capacity

4.4 Type 3999-0096 Filter Regulator

The filter regulator is used to supply compressed air to pneumatic volume boosters for large actuators. It cleans the compressed air, removing any dirt particles, water and oil. In addition, it regulates the air pressure to a constant output pressure.

Technical data

Type	3999-0096
Set point range	Adjustable between 0.5 and 10 bar (8 and 145 psi)
Operating pressure p_1	Max. 16 bar (230 psi)
Version	With mounting bracket
Filter unit	Filter, supply pressure regulator and pressure gauge
Condensate drain	Manually using drain valve
Data Sheet	▶ T 3999-8

4.5 Type 3999-009x Service Unit for purifying and controlling compressed air

The service unit is used to supply compressed air to pneumatic transmitters, controllers and positioners. It cleans the compressed air, removing any dirt particles, water and oil. In addition, it regulates the air pressure to a constant output pressure.

Technical data

Type	3999-009X
Set point range	Adjustable between 0.5 and 10 bar (8 and 145 psi)
Operating pressure p_1	Max. 16 bar (230 psi)
Version	Pipe or wall mounting
Filter unit	Coarse filter, submicro filter, pressure regulator with secondary venting, pressure gauge
Condensate drain	Automatic over float valve or solenoid valve
Options	Pressure switches or differential pressure switches, solenoid valves
Data Sheet	▶ T 3999-6



Fig. 41: Type 3999-0096 Filter Regulator



Fig. 42: Type 3999-009x Service Unit

4.6 Type 3710 Reversing Amplifier

The reversing amplifier allows double-acting pneumatic actuators to be operated using single-acting pneumatic/electro-pneumatic positioners or limit switches.

The positioner creates an output signal pressure Y_1 , to which the air pressure Y_2 is added.

The reversing amplifier uses the supply pressure Z as auxiliary power. The following rule applies:

$$Y_1 + Y_2 = Z$$

Technical data

Type	3710
Supply pressure	Max. 6 bar (90 psi)
Connecting thread	G ¼ or ¼-18 NPT
Ambient temperature range	-25 to +80 °C Low temperature version: -50 to +80 °C and -60 to +80 °C
Degree of protection	IP65
Options	Pressure gauge for Y_1 and Y_2 or a pressure gauge for Y_2 in combination with Type 4708-54 Supply Pressure Regulator
Data Sheet	▶ T 8392



Fig. 43: Type 3710 Reversing Amplifier with two pressure gauges

4.7 Type 3755 Pneumatic Volume Booster

The booster is used together with positioners to increase the positioning speed of pneumatic actuators. It supplies the actuator with an air flow output whose pressure corresponds exactly to the signal pressure, except that it has a much higher volume output.

Versions

- **Type 3755-1:** standard version with a sintered polyethylene filter disk for low-noise venting
- **Type 3755-2:** version with Flanged-on threaded exhaust port connected to a pipe
- Version with stainless steel housing (pending)

Technical data

Type	3755-1	3755-2
Supply pressure	Max. 10 bar (145 psi)	
Signal and actuator pressure	Max. 7 bar (101.5 psi)	
Pressure ratio	Signal: output = 1:1	
Flow coefficient K_{VS}	Exhaust and supply: 2.5 m ³ /h	
Ambient temperature range	-40 to +80 °C -55 to +60 °C ¹⁾	
Connections	G or NPT thread	
Degree of protection	IP44	IP66
Data Sheet	▶ T 8393	

¹⁾ Optional low-temperature version

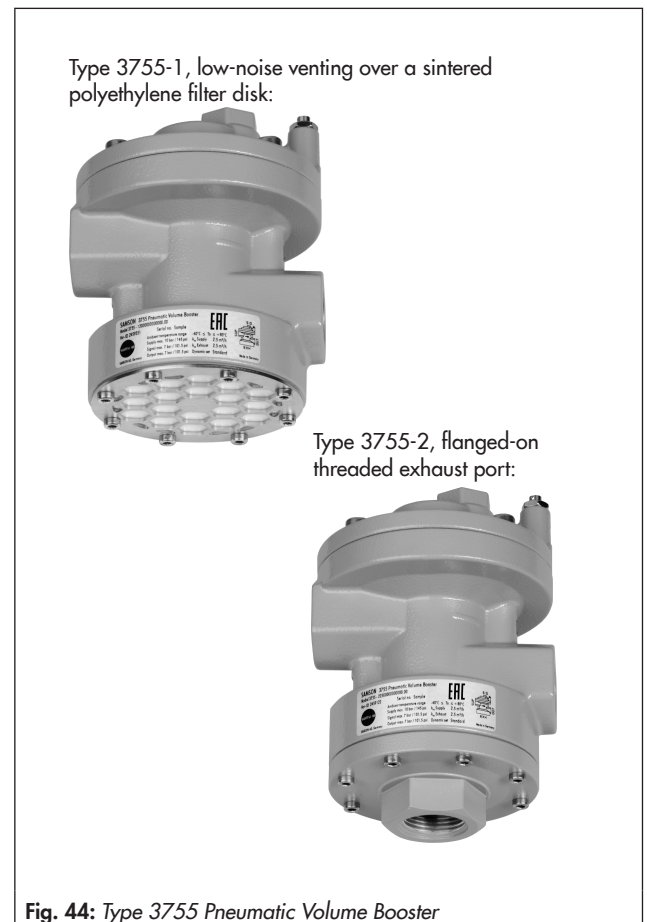

Fig. 44: Type 3755 Pneumatic Volume Booster

4.8 Type 3711 Quick Exhaust Valve

The Type 3711 Quick Exhaust Valve is mounted between the positioner or solenoid valve and the actuator. It is used to vent the actuator more quickly.

The Type 3711 Quick Exhaust Valve functions similar to a 3/2-way valve with an exhaust port. To vent the actuator more quickly, the quick exhaust valve must be mounted as close to the pneumatic actuator as possible.

Versions

- **Type 3711-0:** quick exhaust valve with aluminum body and adjustable restriction
- **Type 3711-1:** quick exhaust valve with stainless steel body and adjustable restriction (pending)

Technical data

Type	3711
Operating pressure	0 to 7 bar
Differential pressure	55 % of control pressure
Exhaust K_{VS}	10 m ³ /h
Ambient temperature range	-40 to +80 °C
Body material	Aluminum (stainless steel pending)
Restriction material	Stainless steel
Seals	VMQ
Data Sheet	▶ T 8547

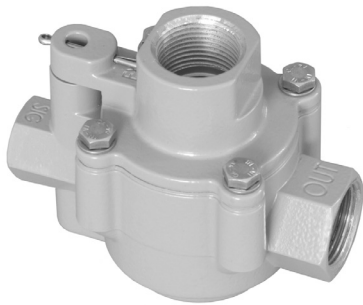

Fig. 45: Type 3711 Quick Exhaust Valve