

## T 8493S EN

### TROVIS SAFE 3793 Smart Positioner (HART®) for on/off valves in safety-instrumented systems



#### Application

Single-acting or double-acting positioner for attachment to pneumatic on/off valves in safety-instrumented systems. Self-calibrating, automatic adaptation to valve and actuator.

<b>Set point</b>	<b>4 to 20 mA</b>
<b>Valve travel</b>	<b>3.6 to 300 mm</b>
<b>Opening angle</b>	<b>24 to 170°</b>

The discrete analysis of the set point  $w$  is performed in automatic mode. The positioner moves the valve to the operating point or fail-safe position depending on the adjustable limits. An automated partial stroke test is started when the set point is between the predefined upper and lower test limits.

TROVIS 3793 Positioner used for throttling service  
▶ T 8493.

#### Special features

- High air capacity
- Modular design: easy retrofitting or exchange of pneumatic or option modules
- Integrated EXPERTplus diagnostics with partial stroke testing for valves in safety-instrumented systems ▶ T 8389-2S
- Simple attachment to all common linear and rotary actuators:
  - SAMSON direct attachment
  - NAMUR rib
  - Attachment to rod-type yokes according to IEC 60534-6-1
  - Attachment according to VDI/VDE 3847
  - Rotary actuator attachment according to VDI/VDE 3845
- Non-contact position sensing
- Plain-text display with NAMUR Recommendation NE 107 states and messages on the device
- Integrated diagnostic functions
- Simple one-knob, menu-driven operation
- LCD easy to read in any mounting position thanks to selectable reading direction
- Configurable with a computer over the SSP interface using the TROVIS-VIEW software

- Variable, automatic start-up with four different initialization modes
- Sub (substitution) initialization mode allows the positioner to be started up in case of emergency whilst the plant is running without having to change the valve position.
- All parameters saved in non-volatile EEPROM
- Two-wire system with a small electrical load of 495  $\Omega$
- Adjustable tight-closing function
- Continuous zero monitoring
- Integrated temperature sensor and operating hours counter
- Self-diagnostics, messages as condensed state conforming to NAMUR Recommendation NE 107
- Pressure sensors to monitor the supply air and signal pressure
- Air capacity adjustable by software



Fig. 1: TROVIS SAFE 3793 Electropneumatic Positioner

## Design and principle of operation

The TROVIS SAFE 3793 Electropneumatic Positioner is mounted on pneumatic control valves and used to assign the valve position (controlled variable  $x$ ) to the control signal (set point  $w$ ). The discrete analysis of the set point  $w$  is performed in automatic mode. The positioner moves the valve to the operating point or fail-safe position depending on the defined limits. An automated step response test is started when the set point is between the predefined upper and lower test limits.

The positioner mainly consists of a non-contact travel sensor system (2), pneumatics and the electronics with the microcontroller (4). The output of the standard version is either single or double acting; which means both the Output 138 and Output 238 can provide the output variable and route the signal pressure to the actuator.

The positioner can be configured to meet requirements of an application by adding a maximum of two pneumatic modules (A, B) and electronic option modules (C, D). The pneumatic modules mainly consist of a microcontroller, which operates an i/p converter with downstream spool valve. Depending on the actuator used, an output of the positioner can be sealed to achieve a single-acting function. The option modules additionally provide individual functions, e.g. recognition of the end positions.

The valve position is transmitted either as an angle of rotation or linear travel to the pick-up lever, from there to the travel sensor (2) and forwarded to the microcontroller (4). The PID algorithm in the microcontroller compares the valve position measured by the travel sensor (2) to the 4 to 20 mA DC control signal issued by the control system after it has been converted by the A/D converter (3). In case of a set point deviation, the pneumatic module (A, B) causes the actuator (1) to be either vented or supplied with air. As a result, the closure member of the valve (e.g. plug) is moved to the position determined by the set point.

The pneumatic module is supplied with air. The flow rate of the module's output can be restricted by software.

The positioner is operated by a rotary pushbutton (9) for menu navigation on the plain-text display (8).

The extended EXPERTplus diagnostics are integrated into the positioner. They provide information on the control valve and positioner and generate diagnostic and status messages, which allow faults to be pinpointed quickly.

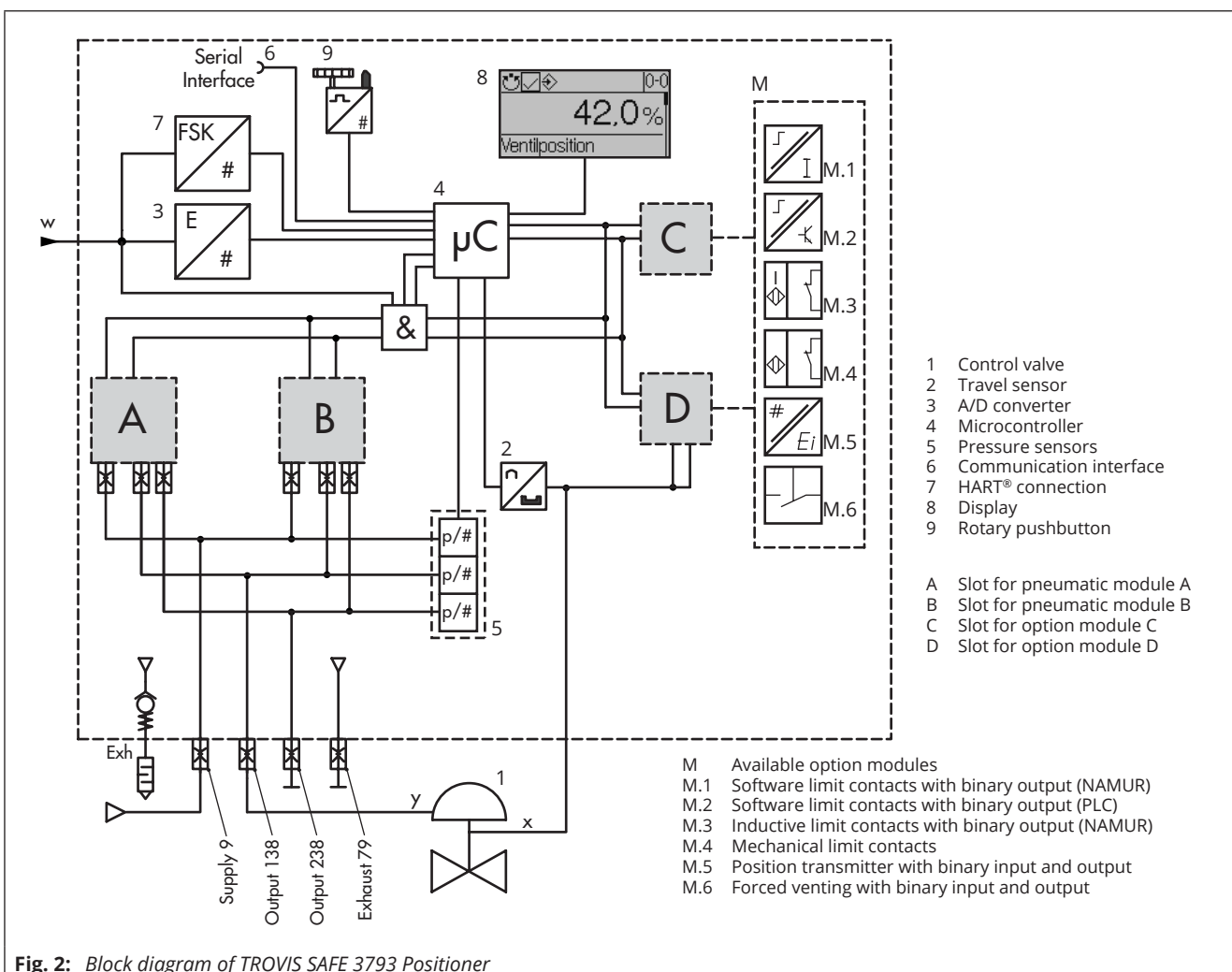

**Technical data · TROVIS SAFE 3793 Positioner**

<b>Travel</b>	
Adjustable travel for	Direct attachment to Type 3277: 3.6 to 30 mm Attachment according to IEC 60534-6 (NAMUR): 5 to 300 mm Attachment according to VDI/VDE 3847-1 5 to 300 mm Attachment according to VDI/VDE 3845 and VDI/VDE 3847-2: 24 to 100° (170° <sup>1)</sup> )
<b>Set point w</b>	
Signal range	4 to 20 mA Two-wire device, reverse polarity protection, split-range operation (can be configured as required, minimum span 4 mA)
Static destruction limit	40 V, internal current limit approx. 40 mA
Minimum current	3.75 mA for display/operation (HART® communication and configuration) 3.90 mA for pneumatic function
Load impedance	≤ 9.9 V (corresponds to 495 Ω at 20 mA)
<b>Supply</b>	
Supply air	2.5 to 10 bar/30 to 150 psi
Air quality acc. to ISO 8573-1	Max. particle size and density: Class 4 Oil content: Class 3 Pressure dew point: Class 3 or at least 10 K below the lowest ambient temperature to be expected
Signal pressure (output)	0 bar up to supply pressure
Hysteresis	≤ 0.3 %
Sensitivity	≤ 0.1 %, adjustable by software
Start-up time	After interrupted operation < 300 ms: 100 ms After interrupted operation > 300 ms: ≤ 2 s
Transit time	Up to 10000 s separately adjustable for exhaust and supply by software
Direction of action	Reversible
Air consumption <sup>2)</sup>	≤ 300 l <sub>n</sub> /h with 6 bar supply pressure, depending on module
Air output capacity (when Δp = 6 bar)	
Actuator (supply)	32 m <sub>n</sub> <sup>3</sup> /h with one pneumatic module (K <sub>V max(20 °C)</sub> = 0.34)
	60 m <sub>n</sub> <sup>3</sup> /h with two pneumatic modules of the same sort (K <sub>V max(20 °C)</sub> = 0.64)
Actuator (exhaust)	37 m <sub>n</sub> <sup>3</sup> /h with one pneumatic module (K <sub>V max(20 °C)</sub> = 0.40)
	70 m <sub>n</sub> <sup>3</sup> /h with two pneumatic modules of the same sort (K <sub>V max(20 °C)</sub> = 0.75)
<b>Environmental conditions and permissible temperatures</b>	
Permissible environmental conditions according to EN 60721-3	
Storage	1K6 (relative humidity ≤ 95 %)
Transport	2K4
Operation	4K4 -20 to +85 °C: All versions -40 to +85 °C: With metal cable glands -55 to +85 °C: Low-temperature versions with metal cable glands Observe the limits in the test certificate for explosion-protected versions.
Resistance to vibration	
Vibrations (sinusoidal)	According to DIN EN 60068-2-6: 0.15 mm, 10 to 60 Hz; 20 m/s <sup>2</sup> , 60 to 500 Hz per axis 0.75 mm, 10 to 60 Hz; 100 m/s <sup>2</sup> , 60 to 500 Hz per axis
Bumps (half sine)	According to DIN EN 60068-2-29: 150 m/s <sup>2</sup> , 6 ms; 4000 bumps per axis
Noise	According to DIN EN 60068-2-64: 10 to 200 Hz: 1 (m/s <sup>2</sup> ) <sup>2</sup> /Hz 200 to 500 Hz: 0.3 (m/s <sup>2</sup> ) <sup>2</sup> /Hz 4 h/axis
Recommended continuous duty	≤ 20 m/s <sup>2</sup>
<b>Influences</b>	
Temperature	≤ 0.15 %/10 K
Supply	None

<sup>1)</sup> On request

<sup>2)</sup> Based on temperature range -40 to +85 °C

Requirements	
EMC	Complying with EN 61000-6-2, EN 61000-6-3, EN 61326-1 and NAMUR Recommendation NE 21
Degree of protection	IP66
Certification according to IEC 61508/SIL	Suitable for use in safety-instrumented systems according to IEC 61511 up to SIL 2 (single device/HFT = 0) and SIL 3 (redundant configuration/HFT = 1) <ul style="list-style-type: none"> <li>Triggered by the set point, emergency venting depending on positioner version at <math>\leq 3.8</math> mA or <math>\leq 4.4</math> mA</li> <li>By the optional 'Forced venting' additional function, emergency venting at <math>&lt; 11</math> V</li> </ul>
Conformity	
Electrical connections	
Cable glands	Max. four, M20x1.5
Terminals	Screw terminals for 0.2 to 2.5 mm <sup>2</sup> wire cross-section (max. 1.5 mm <sup>2</sup> with the option modules)
Explosion protection	
	See "Summary of explosion protection certificates for TROVIS SAFE 3793 Positioner"
Materials	
Housing and cover	Aluminum version: Die-cast aluminum EN AC-ALSi12(Fe) (EN AC-44300) acc. to DIN 1706, chromate and powder coating Stainless steel version: 1.4408
Window	Makrolon® 2807
Cable glands	Polyamide, nickel-plated brass, stainless steel 1.4305
Other external parts	Stainless steel 1.4571 and 1.4404 (316 L)
Communication	
	TROVIS VIEW with SSP/HART® Revision 7
Weight	
	Aluminum: 1.4 to 1.6 kg (depending on version) Stainless steel: 3.2 to 3.4 kg (depending on version)

### Summary of explosion protection certificates for TROVIS SAFE 3793 Positioner

Certification		Type of protection	3793
ATEX	Number BVS 16 ATEX E 117 Date 2016-12-01	II 2G Ex ia IIC T4/T6 Gb / II 2D Ex ia IIIC T85°C Db	-110
		II 2D Ex tb IIIC T85°C Db	-510
		II 3G Ex nA IIC T4/T6 Gc / II 2D Ex tb IIIC T85°C Db	-810
	Number BVS 16 ATEX E 123 Date 2016-12-01	II 3G Ex nA IIC T4/T6 Gc	-850
CCC Ex <sup>1)</sup>	Number 2021322307003872 Date 2023-04-29 Valid until 2026-04-04	Ex ia IIC T4/T6 / Ex ia IIIC T85°C Db	-112
		Ex tb IIIC T85°C Db	-512
CCoE	Number A/P/HQ/MH/104/8178 Date 2024-06-03 Valid until 2028-12-31	Ex ia IIC T4/T6 Gb	-111
EAC-Ex <sup>2)</sup>	Number KZ 7500525.01.01.02374 Date 2026-01-20 Valid until 2031-01-19	1Ex ia IIC T4/T6 Gb / Ex ia IIIC T85°C Db X	-113
		Ex tb IIIC T85°C Db	-513
ECAS-Ex	Number 26-01-178400/ E25-12-182918/NB0007 Date 2026-01-12 Valid until 2027-01-11	Ex ia IIC T4/T6 / Ex ia IIIC T85°C Db	-111
		Ex tb IIIC T85°C Db	-511
		Ex nA IIC T4/T6 Gc / Ex tb IIIC T85°C Db	-811
		Ex nA IIC T4/T6 Gc	-851
IECEX	Number IECEX BVS 16.0084 Date 2021-07-05	Ex ia IIC T4/T6 Gb / Ex ia IIIC T85°C Db	-111
		Ex tb IIIC T85°C Db	-511
		Ex nA IIC T4/T6 Gc / Ex tb IIIC T85°C Db	-811
		Ex nA IIC T4/T6 Gc	-851
FM	Number FM16CA0218 Date 2022-10-18	IS Class I, II, III, Division 1, Groups A, B, C, D, E, F, G; T6/T4 Ta Ex ia IIC T6/T4 Gb Type 4X / NI Class I, II, III, Division 2, Groups A, B, C, D, F, G; T6/T4 Ta Type 4X	-130
	Number FM16US0471 Date 2022-10-18	IS Class I, II, III, Division 1, Groups A, B, C, D, E, F, G; T* Ta* IS Class I, Zone 1, AEx ia IIC T* Gb NI Class I, II, III, Division 2, Groups A, B, C, D, F, G; T* Ta* Type 4X / Class I, Zone 1, AEx ia IIC; Type 4X	
NEPSI <sup>1)</sup>	Number GYJ23.1093X Date 2023-04-29 Valid until 2028-04-28	Ex ia IIC T4/T6 Gb / Ex ia IIIC T85°C Db	-112
		Ex tb IIIC T85°C Db	-512

<sup>1)</sup> Only TROVIS SAFE 3793 with hardware version HV 01.00.xx and firmware version FV 01.00.xx

<sup>2)</sup> Only TROVIS SAFE 3793 with hardware version HV 02.00.xx and firmware version FV 01.01.xx

## Technical data · Optional additional functions

<b>Analog position transmitter</b>		
Version	Two-wire system, galvanic isolation, reverse polarity protection, reversible direction of action	
Supply	10 to 30 V DC	
Output signal	4 to 20 mA	
Error indication	2.4 or 21.6 mA (action differs from the specification in NAMUR Recommendation NE 43)	
No-load current	1.4 mA	
Static destruction limit	38 V DC · 30 V AC	
<b>Software limit contacts</b>		
	NAMUR	PLC
Version	Galvanic isolation, reverse polarity protection, switching output acc. to EN 60947-5-6	Galvanic isolation, reverse polarity protection, binary input of a PLC acc. to EN 61131-2, $P_{max} = 400 \text{ mW}$
Signal state	Non-conducting $\leq 1.0 \text{ mA}$ Conducting $\geq 2.2 \text{ mA}$	Non-conducting Conducting ( $R = 348 \Omega$ )
Static destruction limit	32 V DC/24 V AC	16 V DC/50 mA
<b>Binary output</b>		
	NAMUR	PLC
Version	Galvanic isolation, reverse polarity protection, switching output acc. to EN 60947-5-6	Galvanic isolation, reverse polarity protection, binary input of a PLC acc. to EN 61131-2, $P_{max} = 400 \text{ mW}$
Signal state	Non-conducting $\leq 1.0 \text{ mA}$ Conductive $\geq 2.2 \text{ mA}$	Non-conducting Conducting ( $R = 348 \Omega$ )
Static destruction limit	32 V DC/24 V AC	16 V DC/50 mA
<b>Binary input (24 V)</b>		
Version	Galvanic isolation, reverse polarity protection	
Voltage input	0 to 24 V DC	
Input resistance	$\geq 7 \text{ k}\Omega$	
ON switching state	$U_e > 18 \text{ V}$	
OFF switching state	$U_e < 11 \text{ V}$	
Static destruction limit	38 V DC/30 V AC	
<b>Binary input (contact)</b>		
Version	For external switch (floating contact) or relay contact Galvanic isolation	
Open-circuit voltage	Max. 10 V (when contact is open)	
Current draw	Max. 100 mA (pulsed when contact is closed)	
Contact	Closed: $R < 5 \Omega$ ; open: $R > 300 \Omega$	
Static destruction limit	38 V DC	
<b>Analog input <sup>1)</sup></b>		
Input	4 to 20 mA, galvanic isolation, reverse polarity protection	
Load	$< 4.3 \text{ V}$	
Current limit	33 mA	
<b>Forced venting</b> · Approval acc. to IEC 61508/SIL		
Version	Galvanic isolation, reverse polarity protection	
Voltage input	0 to 24 V DC	
Input current	At $V_{in} = 24 \text{ V}$ : approx. 7 mA In the switching point (at approx. 13 V): approx. 3.3 mA	
Signal state	Active $U_e < 11 \text{ V}$ Not active $U_e > 18 \text{ V}$	
Static destruction limit	38 V DC/30 V AC	
<b>Inductive limit contacts</b>		
Version	For connection to switching amplifier according to EN 60947-5-6, SJ2-SN proximity switches, reverse polarity protection	
Measuring plate not detected	$\geq 3 \text{ mA}$	
Measuring plate detected	$\leq 1 \text{ mA}$	
Static destruction limit	20 V DC	
Permissible ambient temperature	$-50 \text{ to } +85 \text{ }^\circ\text{C}$	

Mechanical limit contacts	
Floating contact	NC contact/NO contact
Static destruction limit	38 V DC · 30 V AC · 0.2 A
Permissible ambient temperature	-40 to +85 °C
External position sensor I <sup>1)</sup>	
Version	For connection to an external position sensor (SAMSON)
Permissible ambient temperature	T4: -30 to +80 °C
	T6: -30 to +55 °C
	T 85°C: -30 to +55 °C
External position sensor II (4 to 20 mA) <sup>1)</sup>	
Input	4 to 20 mA, galvanic isolation, reverse polarity protection
Load	<4.3 V
Current limit	33 mA

<sup>1)</sup> Only TROVIS SAFE 3793 with hardware version HV 02.00.xx and firmware version FV 01.01.xx

## Pressure sensors

Pressure sensors	
Pressure range	0 to 14 bar
Permissible ambient temperature	-40 to +85 °C

## Mounting the positioner

The positioner can be attached directly to the Type 3277 Actuator (240 to 750 cm<sup>2</sup>) over a connection block. In actuators with "actuator stem extends" fail-safe action, the signal pressure is routed over an internal hole in the actuator yoke to the actuator. In actuators with "actuator stem retracts" fail-safe action, the signal pressure is routed to the actuator over ready-made external piping.

Using the appropriate bracket, the positioner can also be attached according to IEC 60534-6-1 (NAMUR recommendation). The positioner can be mounted on either side of the control valve.

A pair of universal brackets is used for the attachment to Type 3278 Rotary Actuators or other rotary actuators according to VDI/VDE 3845. The rotary motion of the actuator is transferred to the positioner over a coupling wheel with travel indication.

A special version of the positioner allows it to be attached according to VDI/VDE 3847. This type of attachment allows the positioner to be replaced quickly while the process is running by blocking the air in the actuator. The positioner can be attached directly to the Type 3277 Actuator using an adapter bracket or adapter block. Alternatively, it can be attached to the NAMUR rib of a control valve using an additional NAMUR connection block.

## Version

The TROVIS SAFE 3793 Electropneumatic Positioner can be used as a single or double-acting positioner, depending on the combination of the available pneumatic modules.

The modular design also allows diverse optional additional functions (option modules) to be added and adapt the positioner on site to the specific requirements.

- **TROVIS SAFE 3793** · Electropneumatic positioner for on/off valves, HART® communication, on-site operation, local communication with SSP interface, EXPERTplus diagnostics, pressure sensors to monitor the supply air and signal pressure

## Optional modules

The modular design of the TROVIS SAFE 3793 Positioner allows it to be adapted to specific requirements. The air capacity and direction of action can be varied by the installation of different pneumatic modules (Fig. 3). Optional additional functions are available by using option modules (Fig. 4 and Fig. 5).

If the positioner is ordered with additional pneumatic modules and/or option modules, they are ready installed and connected upon delivery.

**Table 1:** Available pneumatic modules

Article code	Function
P3799-0000 <sup>1)</sup>	Dummy module (seals the slot connections and must be used when only one pneumatic module is installed)
P3799-0001 <sup>1)</sup>	Output 138 and Output 238 module (single and double acting)
P3799-0002 <sup>1)</sup>	Output 138 module (single acting)
P3799-0003 <sup>1)</sup>	Output 238 module (single acting)
P3799-0004	Module Output 138 (fail-in-place function)

<sup>1)</sup> SIL approval according to IEC 61508

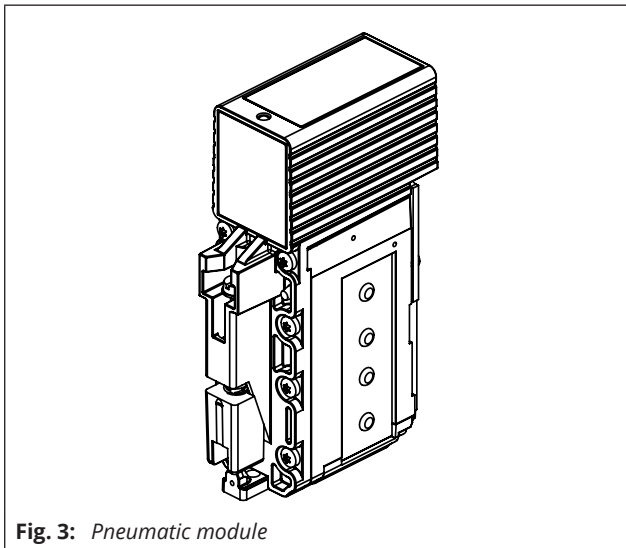

Fig. 3: Pneumatic module

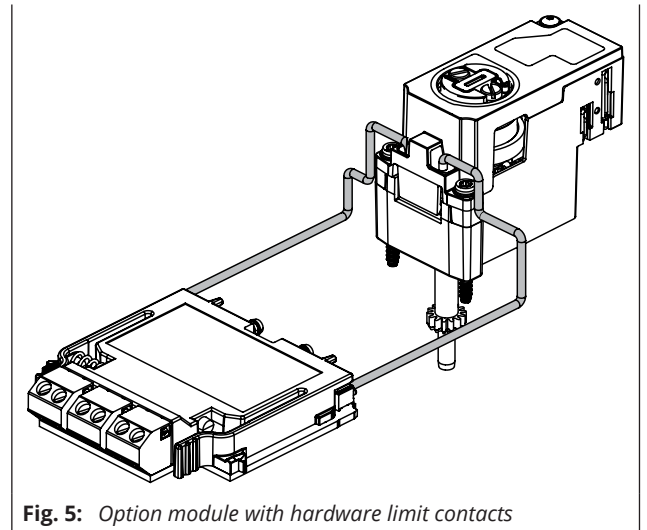

Fig. 5: Option module with hardware limit contacts

Table 2: Available option modules

Article code	Function											
	Software limit contacts (NAMUR)	Software limit contacts (PLC)	Inductive limit contacts	Mechanical limit contacts	Analog position transmitter	External position sensor I	External position sensor II	Binary input (contact)	Binary input (24 V)	Forced venting	Binary output	Analog input
Z3799-00000												
Z3799-xxx10	•											
Z3799-xxx11		•										
Z3799-xxx15			•									
Z3799-xxx21 <sup>1)</sup>				•								
Z3799-xxx30					•							
Z3799-xxx40						•						
Z3799-xxx50 <sup>1)</sup>							•					
Z3799-xxx60 <sup>1)</sup>								•				
Z3799-xxx65 <sup>1)</sup>									•			
Z3799-xxx80										•	•	
Z3799-xxx90 <sup>1)</sup>												•

<sup>1)</sup> Only TROVIS 3793 with hardware version HV 02.00.xx and firmware version FV 01.01.xx

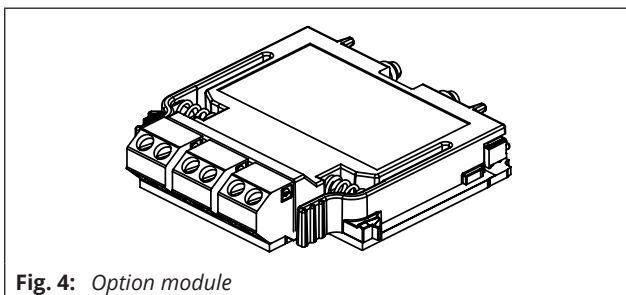

Fig. 4: Option module

### Operation

The positioner is operated using one proven, user-friendly rotary pushbutton: the various menu levels, parameters and values are selected by turning the button. By pressing the button, the required setting is activated. All parameters can be checked and changed on site.

All values are displayed on the plain-text display. The reading direction of the display can be rotated by 180°.

The initialization key activates initialization which is started according to the ready adjusted parameters (autotune). After initialization is completed, the positioner immediately starts closed-loop operation.

To configure the positioner with SAMSON's TROVIS-VIEW software, the positioner is equipped with an additional digital interface to be connected to the USB interface of a computer using an adapter.

Additionally, all parameters of the TROVIS SAFE 3793 Positioner can be accessed using HART® communication.

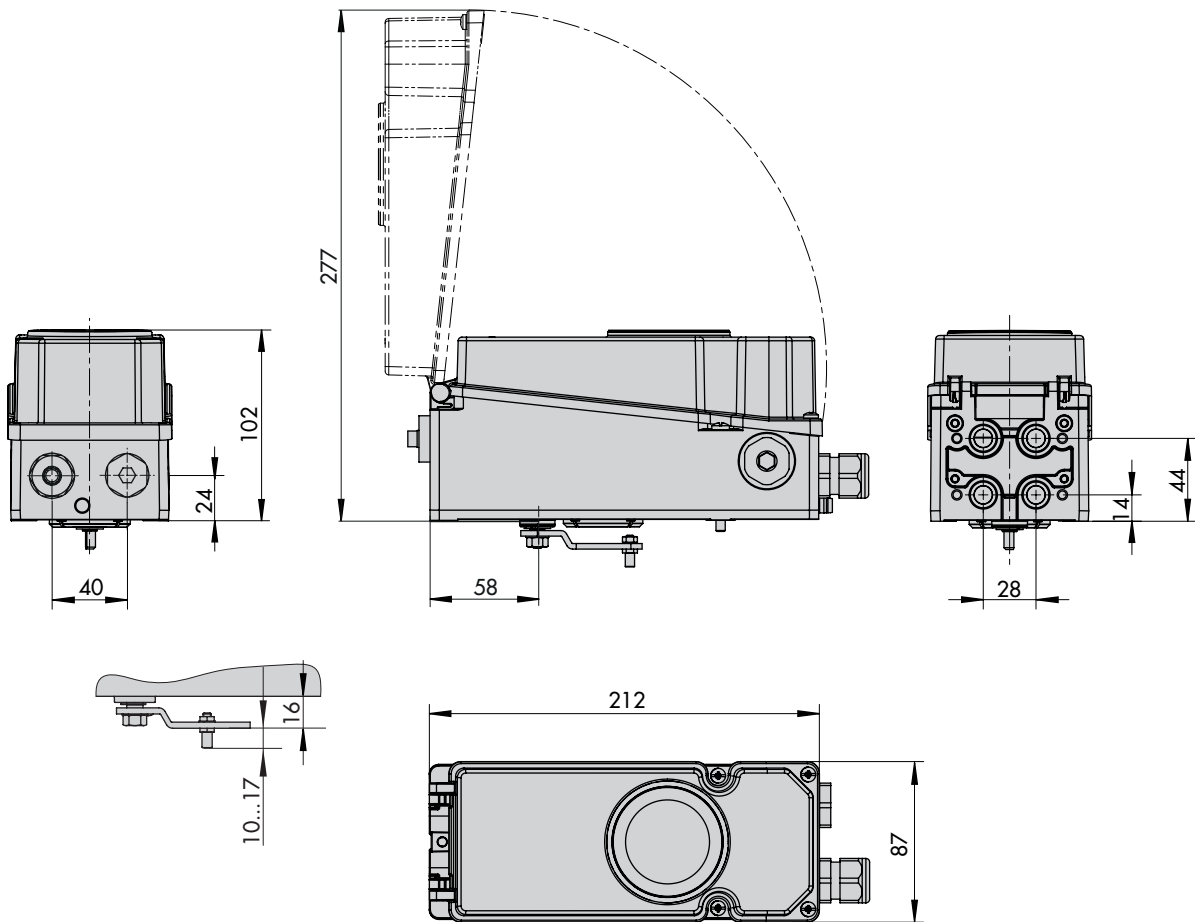

**Attachment according to IEC 60534-6 (NAMUR)**

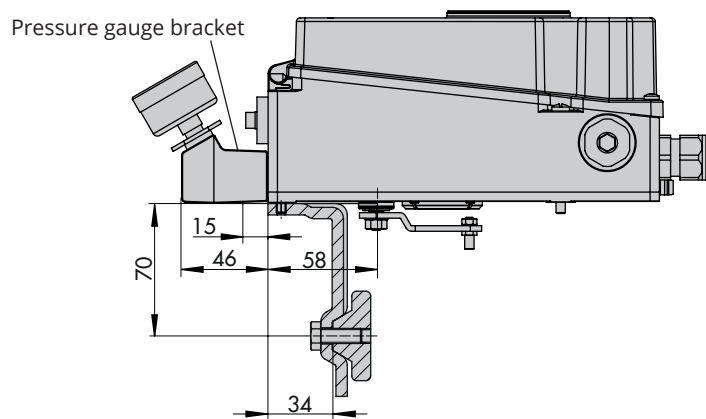

**Attachment according to VDI/  
VDE 3847 onto Type 3277 Actuator**

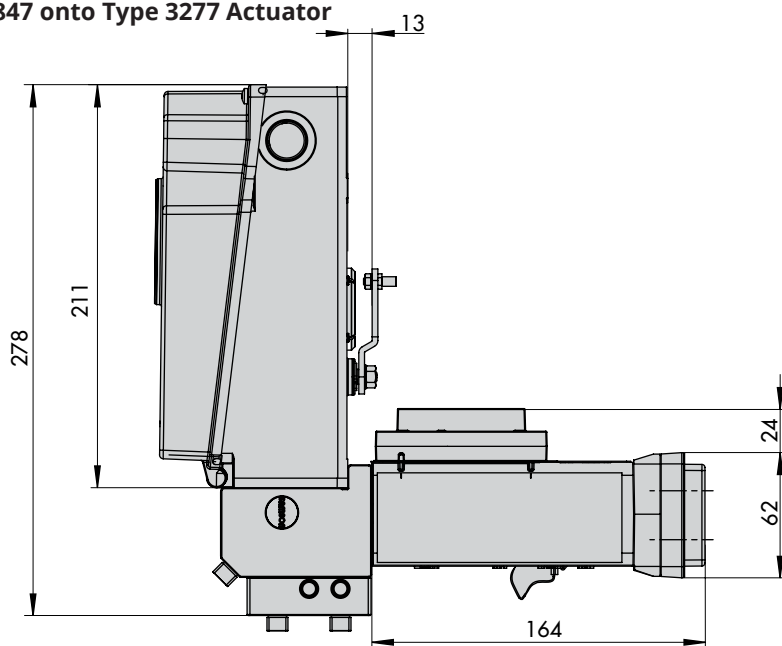

**Attachment according to VDI/VDE 3847  
to a NAMUR rib**

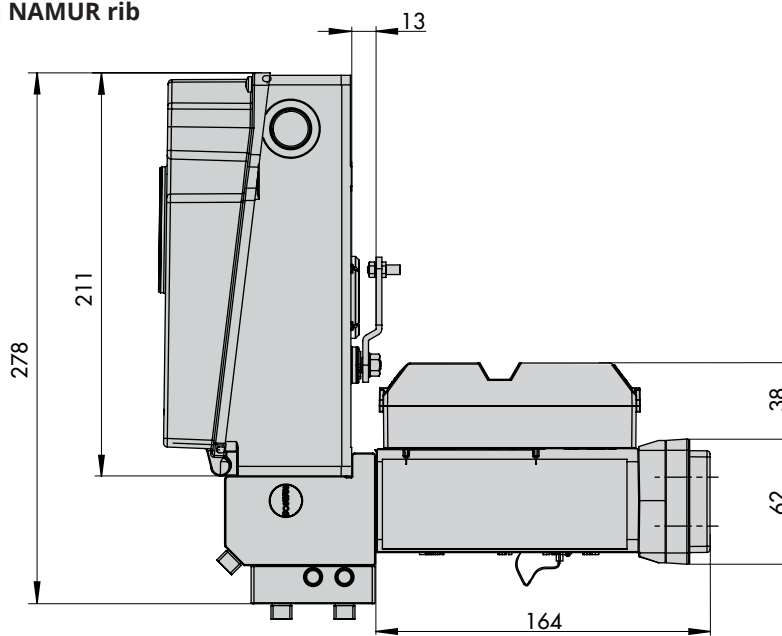

## Attachment to rotary actuators according to VDI/VDE 3845

Fixing level 1, AA1 to AA4 size

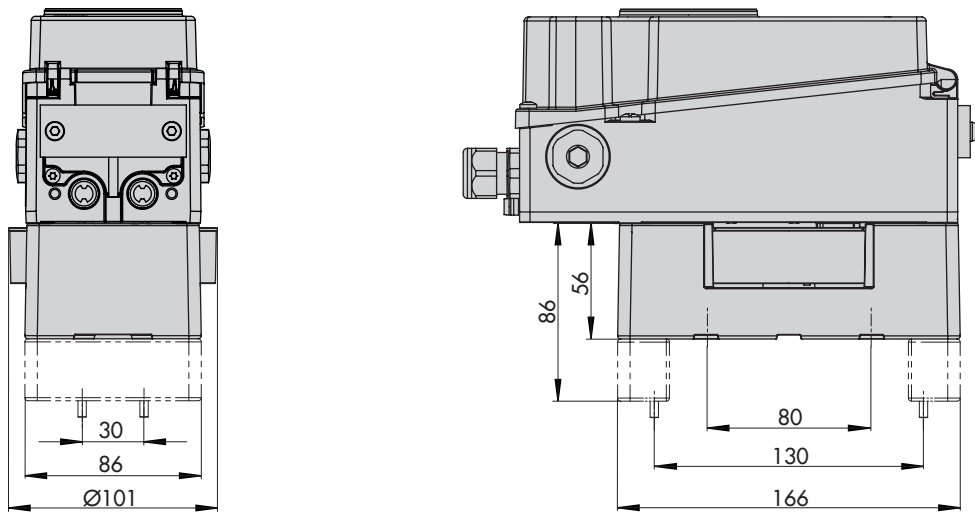

### Lever

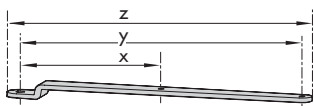

Lever	x	y	z
M	25 mm	50 mm	66 mm
L	70 mm	100 mm	116 mm
XL	100 mm	200 mm	216 mm
XXL	200 mm	300 mm	316 mm

### Fixing levels according to VDI/VDE 3845 (September 2010)

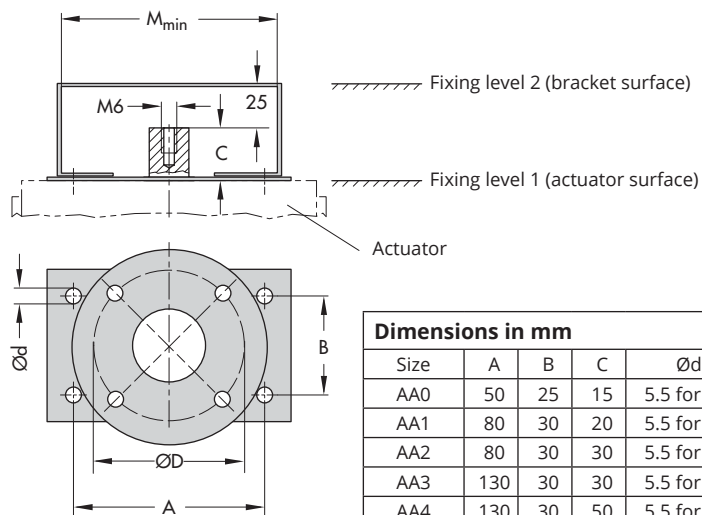

#### Dimensions in mm

Size	A	B	C	Ød	M <sub>min</sub>	D <sup>1)</sup>
AA0	50	25	15	5.5 for M5	66	50
AA1	80	30	20	5.5 for M5	96	50
AA2	80	30	30	5.5 for M5	96	50
AA3	130	30	30	5.5 for M5	146	50
AA4	130	30	50	5.5 for M5	146	50
AA5	200	50	80	6.5 for M6	220	50

<sup>1)</sup> Flange type F05 acc. to DIN EN ISO 5211

**Pressure gauge bracket, two pressure gauges**

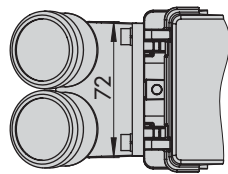
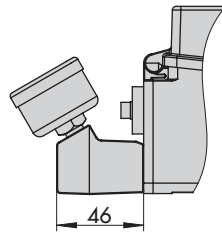

**Pressure gauge bracket, three pressure gauges**

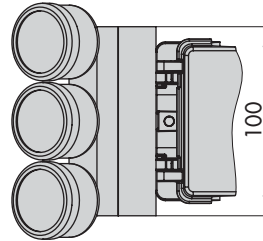
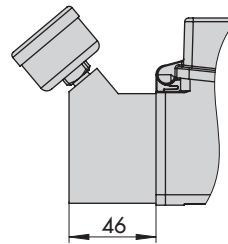

**Connecting plate**

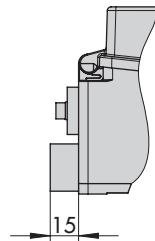

**Electrical connection**

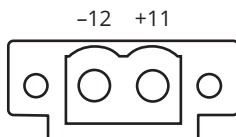

Set point (mA signal)

**Table 3: Slot position and terminal assignment of the option modules**

Z3799-xxx10 [N] · Software limit contacts with binary output (NAMUR)				
Slot	Terminal assignment			
C or D				
	<b>Description</b>	<b>Terminal</b>		
	Software limit contact 1 (NAMUR)	N	+45 -46	
	Software limit contact 2 (NAMUR)	N	+55 -56	
Binary output (NAMUR)	N	+83 -84		
Z3799-xxx11 [X] · Software limit contacts with binary output (PLC)				
Slot	Terminal assignment			
C or D				
	<b>Description</b>	<b>Terminal</b>		
	Software limit contact 1 (PLC)	X	+91 -92	
	Software limit contact 2 (PLC)	X	+93 -94	
Binary output (PLC)	X	+95 -96		
Z3799-xxx15 [P] · Inductive limit contacts with binary output (NAMUR)				
Slot	Terminal assignment			
D				
	<b>Description</b>	<b>Terminal</b>		
	Binary output (NAMUR)	P	+83 -84	
	Inductive limit contact 1	P	+41 -42	
Inductive limit contact 2	P	+51 -52		
Z3799-xxx21 [F] · Inductive limit contacts and forced venting <sup>1)</sup>				
Slot	Terminal assignment			
D				
	<b>Description</b>	<b>Terminal</b>		
	Forced venting	M	+81 -82	
	Inductive limit contact 1	M	+41 -42	
Inductive limit contact 2	M	+51 -52		
Z3799-xxx30 [M] · Mechanical limit contacts				
Slot	Terminal assignment			
D				
	<b>Description</b>	<b>Switching function</b>	<b>Terminal</b>	
	Mechanical limit contact 1 (changeover contact)	NC	M	47
		C		48
		NO		49
	Mechanical limit contact 2 (changeover contact)	NC	M	57
C		58		
NO		59		

**Z3799-xxx40 [T]** · Position transmitter with binary input (24 V) and binary output (NAMUR)

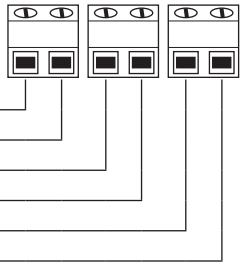
Slot	Terminal assignment									
C or D										
	<table border="1"> <thead> <tr> <th>Description</th> <th>Terminal</th> </tr> </thead> <tbody> <tr> <td>Position transmitter 4 to 20 mA</td> <td>T +31 -32</td> </tr> <tr> <td>Binary input 24 V</td> <td>T +87 -88</td> </tr> <tr> <td>Binary output (NAMUR)</td> <td>T +83 -84</td> </tr> </tbody> </table>	Description	Terminal	Position transmitter 4 to 20 mA	T +31 -32	Binary input 24 V	T +87 -88	Binary output (NAMUR)	T +83 -84	
Description	Terminal									
Position transmitter 4 to 20 mA	T +31 -32									
Binary input 24 V	T +87 -88									
Binary output (NAMUR)	T +83 -84									

**Z3799-xxx50 [E]** · External position sensor I <sup>1)</sup>

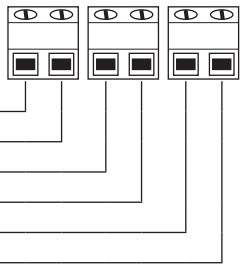
Slot	Terminal assignment																		
D																			
	<table border="1"> <thead> <tr> <th>Description</th> <th>Terminal</th> <th>Color</th> </tr> </thead> <tbody> <tr> <td rowspan="2">Shunt terminal (jumpered)</td> <td>E N</td> <td></td> </tr> <tr> <td>N</td> <td></td> </tr> <tr> <td rowspan="4">External position sensor</td> <td>E 21</td> <td>Blue</td> </tr> <tr> <td>22</td> <td>Brown</td> </tr> <tr> <td>23</td> <td>White</td> </tr> <tr> <td>24</td> <td>Black</td> </tr> </tbody> </table>	Description	Terminal	Color	Shunt terminal (jumpered)	E N		N		External position sensor	E 21	Blue	22	Brown	23	White	24	Black	
Description	Terminal	Color																	
Shunt terminal (jumpered)	E N																		
	N																		
External position sensor	E 21	Blue																	
	22	Brown																	
	23	White																	
	24	Black																	

**Z3799-xxx60 [Y]** · External position sensor II (4 to 20 mA) and binary output (NAMUR) <sup>1)</sup>

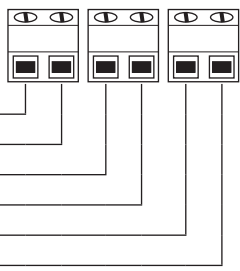
Slot	Terminal assignment									
D										
	<table border="1"> <thead> <tr> <th>Description</th> <th>Terminal</th> </tr> </thead> <tbody> <tr> <td>External position sensor (4 to 20 mA)</td> <td>Y +15 -16</td> </tr> <tr> <td>Shunt terminal (jumpered)</td> <td>Y N N</td> </tr> <tr> <td>Binary output (NAMUR)</td> <td>Y +83 -84</td> </tr> </tbody> </table>	Description	Terminal	External position sensor (4 to 20 mA)	Y +15 -16	Shunt terminal (jumpered)	Y N N	Binary output (NAMUR)	Y +83 -84	
Description	Terminal									
External position sensor (4 to 20 mA)	Y +15 -16									
Shunt terminal (jumpered)	Y N N									
Binary output (NAMUR)	Y +83 -84									

**Z3799-xxx65 [U]** · Binary input (contact), binary input (24 V) and binary output (NAMUR) <sup>1)</sup>

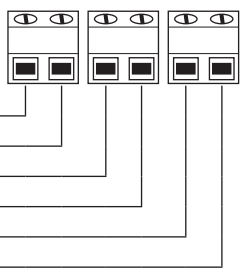
Slot	Terminal assignment										
C or D											
	<table border="1"> <thead> <tr> <th>Description</th> <th>Terminal</th> </tr> </thead> <tbody> <tr> <td rowspan="2">Binary input contact</td> <td>N 85 86</td> </tr> <tr> <td></td> </tr> <tr> <td>Binary input 24 V</td> <td>N +87 -88</td> </tr> <tr> <td>Binary output (NAMUR)</td> <td>N +83 -84</td> </tr> </tbody> </table>	Description	Terminal	Binary input contact	N 85 86		Binary input 24 V	N +87 -88	Binary output (NAMUR)	N +83 -84	
Description	Terminal										
Binary input contact	N 85 86										
Binary input 24 V	N +87 -88										
Binary output (NAMUR)	N +83 -84										

**Z3799-xxx80 [V]** · Forced venting with binary input (24 V) and binary output (NAMUR)

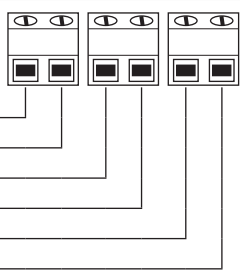
Slot	Terminal assignment										
C or D											
	<table border="1"> <thead> <tr> <th>Description</th> <th>Terminal</th> </tr> </thead> <tbody> <tr> <td rowspan="2">Forced venting</td> <td>V +81 -82</td> </tr> <tr> <td></td> </tr> <tr> <td>Binary input 24 V</td> <td>V +87 -88</td> </tr> <tr> <td>Binary output (NAMUR)</td> <td>V +83 -84</td> </tr> </tbody> </table>	Description	Terminal	Forced venting	V +81 -82		Binary input 24 V	V +87 -88	Binary output (NAMUR)	V +83 -84	
Description	Terminal										
Forced venting	V +81 -82										
Binary input 24 V	V +87 -88										
Binary output (NAMUR)	V +83 -84										

**Z3799-xxx90 [A]** · Analog input and binary output (NAMUR) <sup>1)</sup>

Slot	Terminal assignment								
C or D	<table border="1"> <thead> <tr> <th>Description</th> <th>Terminal</th> </tr> </thead> <tbody> <tr> <td>Analog input 4 to 20 mA</td> <td>A +17 -18</td> </tr> <tr> <td>Shunt terminal (jumpered)</td> <td>A N N</td> </tr> <tr> <td>Binary output (NAMUR)</td> <td>A +83 -84</td> </tr> </tbody> </table>	Description	Terminal	Analog input 4 to 20 mA	A +17 -18	Shunt terminal (jumpered)	A N N	Binary output (NAMUR)	A +83 -84
Description	Terminal								
Analog input 4 to 20 mA	A +17 -18								
Shunt terminal (jumpered)	A N N								
Binary output (NAMUR)	A +83 -84								

<sup>1)</sup> Only TROVIS SAFE 3793 with hardware version HV 02.00.xx and firmware version FV 01.01.xx

**Article code**

TROVIS SAFE 3793 with hardware version HV 02.00.xx and firmware version FV 01.01.xx

Positioner	TROVIS SAFE 3793- x x x 5 x x x x x x x 0 0 x x x x 0 x 0 0 x x x x
With LCD, autotune, HART® communication	
Explosion protection	
Without	0 0 0
<b>ATEX</b>	
II 2G Ex ia IIC T4/T6 Gb / II 2D Ex ia IIIC T 85°C Db	1 1 0
II 2D Ex tb IIIC T 85°C Db	5 1 0
II 3G Ex nA IIC T4/T6 Gc / II 2 D Ex tb IIIC T 85°C Db	8 1 0
II 3G Ex nA IIC T4/T6 Gc	8 5 0
<b>CCoE</b>	
Ex ia IIC T4/T6 Gb	1 1 1
<b>EAC Ex</b>	
1Ex ia IIC T4/T6 Gb / Ex ia IIIC T85°C Db X	1 1 3
Ex tb IIIC T85°C Db	5 1 3
<b>ECAS-Ex</b>	
Ex ia IIC T4/T6 / Ex ia IIIC T85°C Db	1 1 1
Ex tb IIIC T85°C Db	5 1 1
Ex nA IIC T4/T6 Gc / Ex tb IIIC T85°C Db	8 1 1
Ex nA IIC T4/T6 Gc	8 5 1
<b>IECEX</b>	
Ex ia IIC T4/T6 Gb / Ex ia IIIC T85 °C Db	1 1 1
Ex tb IIIC T 85°C Db	5 1 1
Ex nA IIC T4/T6 Gc / Ex tb IIIC T85 °C Db	8 1 1
Ex nA IIC T4/T6 Gc	8 5 1
<b>FM</b>	
IS Class I, II, III, Division 1, Groups A, B, C, D, E, F, G; T6/T4 Ta Ex ia IIC T6/T4 Gb; Type 4X	1 3 0
NI Class I, II, III, Division 2, Groups A, B, C, D, F, G; T6/T4 Ta Type 4X	
IS Class I, II, III, Division 1, Groups A, B, C, D, E, F, G; T6/T4 Ta IS Class I, Zone 1, AEx ia IIC T6/T4 Gb	
NI Class I, II, III, Division 2, Groups A, B, C, D, F, G; T6/T4 Ta; Type 4X Class I, Zone 1, AEx ia IIC; Type 4X	
Pneumatics	
Single/double acting, K <sub>v</sub> = 0.35	0 1
Single/double acting, K <sub>v</sub> = 0.70	0 2
Single acting, 2x independent K <sub>v</sub> = 0.35	0 3
Fail-in-place module, single acting K <sub>v</sub> = 0.35	2 0
Option module 1 (slot C)	
Without/dummy module	0 0
Software limit contacts + binary output (NAMUR), [N]	1 0
Software limit contacts + Binary output (PLC), [X] <sup>1)</sup>	1 1
Position transmitter + binary input (24 V DC) + binary output (NAMUR), [T]	4 0
Binary input (floating contact) + binary input (24 V DC) + binary output (NAMUR), [U]	6 5
Forced venting + binary input (24 V DC) + binary output (NAMUR), [V]	8 0
Analog input (4 to 20 mA) + binary output (NAMUR), [A]	9 0
Option module 2 (slot D)	
Without/dummy module	0 0
Software limit contacts + binary output (NAMUR), [N]	1 0

Positioner	TROVIS SAFE 3793- x x x 5 x x x x x x x 0 0 x x x 0 x 0 x x x x															
Software limit contacts + Binary output (PLC), [X] <sup>1)</sup>	1	1														
Inductive limit contacts (NAMUR NC) + binary output (NAMUR), [P]; -50 to +85 °C	1	5														
Inductive limit contacts (NAMUR NC) + forced venting, [F]; -50 to +85 °C	2	1											9	8		
Mechanical limit contacts, [M]; -40 to +85 °C	3	0														
Position transmitter + binary input (24 V DC) + binary output (NAMUR), [T]	4	0														
External position sensor I (with sensor and 10 m connecting cable), [E]; -30 to +85 °C	5	0											9	8		
External position sensor I (without sensor and connecting cable), [E]; -30 to +85 °C	5	1											9	8		
External position sensor II (4 to 20 mA) + binary output (NAMUR), [Y]	6	0											9	8		
Binary input (floating contact) + binary input (24 V DC) + binary output (NAMUR), [U]	6	5											9	8		
Analog input (4 to 20 mA) + binary output (NAMUR), [A]	9	0											9	8		
Pressure sensors																
Without	0															
Standard (Supply 9, Output 138, Output 238)	1/2															
Electrical connection																
M20x1.5 (1x cable gland, 3x blanking plugs)	1															
Housing material																
Aluminum (standard)	0															
Stainless steel 1.4408	1															
Special applications																
Without	0															
Additional certification																
Without	0															
SIL						1	0/1						9	8		
Permissible ambient temperature																
Standard: -20 to +85 °C, plastic cable gland							0									
-40 to +85 °C metal cable gland							1									
-55 to +85 °C, low-temperature version with metal cable gland							2									
Emergency shutdown																
3.8 mA								0								
4.4 mA								1					9	8		
Display text in different languages																
Standard (English, German, French)									0							
Special version																
Without										0						
Cover without window											1					
Hardware version																
02.00.00 <sup>2)</sup>		2											9	8		
G1.00 <sup>3)4)</sup>		0/1											9	9		
Software version																
1 January 2016		2											9	8	9	4
01.00.16 <sup>4)</sup>		0/1											9	9	9	6

<sup>1)</sup> The option module for *Software limit contacts + Binary output (PLC), [X]* is not available in the explosion-protection version.

<sup>2)</sup> The hardware version 02.00.00 is only compatible with firmware version 01.01.xx (downdating to version 01.00.xx is not possible).

<sup>3)</sup> The hardware version G1.00 is only compatible with firmware version 01.00.xx (updating to version 01.01.16 is not possible).

<sup>4)</sup> Information on TROVIS SAFE 3793 Positioner with hardware version G1.00 and firmware version 01.00.xx can be found in the corresponding Mounting and Operating Instructions ► EB 8493S for firmware version 01.00.xx

Positioner	TROVIS SAFE 3793- x x x 5 x x x x x x x x 0 0 0 x 0 x 0 x 0 0 9 9 x x	
With LCD, autotune, HART® communication		
Explosion protection		
Without	0 0 0	
-----		
<b>ATEX</b>	II 2G Ex ia IIC T4/T6 Gb / II 2D Ex ia IIIC T 85°C Db	1 1 0
	II 2D Ex tb IIIC T 85°C Db	5 1 0
	II 3G Ex nA IIC T4/T6 Gc / II 2 D Ex tb IIIC T 85°C Db	8 1 0
	II 3G Ex nA IIC T4/T6 Gc	8 5 0
-----		
<b>CCC Ex</b>	Ex ia IIC T4/T6 / Ex ia IIIC T85°C Db	1 1 2
	Ex tb IIIC T85°C Db	5 1 2
-----		
<b>CCoE</b>	Ex ia IIC T4/T6 Gb	1 1 1
	Ex ia IIC T4/T6 / Ex ia IIIC T85°C Db	1 1 1
-----		
<b>ECAS-Ex</b>	Ex tb IIIC T85°C Db	5 1 1
	Ex nA IIC T4/T6 Gc / Ex tb IIIC T85°C Db	8 1 1
	Ex nA IIC T4/T6 Gc	8 5 1
	Ex ia IIC T4/T6 Gb / Ex ia IIIC T85 °C Db	1 1 1
-----		
<b>IECEX</b>	Ex tb IIIC T 85°C Db	5 1 1
	Ex nA IIC T4/T6 Gc / Ex tb IIIC T85 °C Db	8 1 1
	Ex nA IIC T4/T6 Gc	8 5 1
	IS Class I, II, III, Division 1, Groups A, B, C, D, E, F, G; T6/T4 Ta Ex ia IIC T6/T4 Gb; Type 4X NI Class I, II, III, Division 2, Groups A, B, C, D, F, G; T6/T4 Ta Type 4X	1 3 0
-----		
<b>FM</b>	IS Class I, II, III, Division 1, Groups A, B, C, D, E, F, G; T6/T4 Ta IS Class I, Zone 1, AEx ia IIC T6/T4 Gb NI Class I, II, III, Division 2, Groups A, B, C, D, F, G; T6/T4 Ta; Type 4X Class I, Zone 1, AEx ia IIC; Type 4X	1 3 0
	Ex ia IIC T4/T Gb / Ex ia IIIC T85°C Db	1 1 2
-----		
<b>NEPSI</b>	Ex tb IIIC T85°C Db	5 1 2
Pneumatics		
Single/double acting, $K_v = 0.35$	0 1	
Single/double acting, $K_v = 0.70$	0 2	
Single acting, 2x independent $K_v = 0.35$	0 3	
Option module 1 (slot C)		
Without/dummy module	0 0	
Software limit contacts + binary output (NAMUR), [N]	1 0	
Software limit contacts + Binary output (PLC), [X] <sup>1)</sup>	1 1	
Position transmitter + binary input/output (NAMUR), [T]	4 0	
Forced venting + Binary input/output (NAMUR), [V]	8 0	
Option module 2 (slot D)		
Without/dummy module	0 0	
Software limit contacts + binary output (NAMUR), [N]	1 0	
Software limit contacts + Binary output (PLC), [X] <sup>1)</sup>	1 1	
Inductive limit contacts + binary output (NAMUR), [P]; -50 to +85 °C	1 5	
Mechanical limit contacts, [M]; -40 to +85 °C	3 0	
Position transmitter + binary input/output (NAMUR), [T]	4 0	
Pressure sensors		
Without	0	
Standard (Supply 9, Output 138, Output 238); -40 to +85 °C	1	
Electrical connection		
M20x1.5 (1x cable gland, 3x blanking plugs)	1	
½-14 NPT (1x cable gland, 3x blanking plugs)	4	
Housing material		
Aluminum (standard)	0	
Special applications		
Without	0	
Additional certification		
Without	0	

Positioner	TROVIS SAFE 3793- x x x 5 x x x x x x x x 0 0 0 x 0 x 0 x 0 0 9 9 x x									
Permissible ambient temperature										
Standard: -20 to +85 °C, plastic cable gland	0									
-40 to +85 °C metal cable gland	1									
-55 to +85 °C, low-temperature version with metal cable gland	2									
Display text in different languages										
Standard (English and German)	0									
Special version										
Without							0			
Cover without window							1			
Hardware version										
1.00.00								9	9	
Firmware version										
1.00.05										9 6

<sup>1)</sup> The option module for *Software limit contacts + Binary output (PLC), [X]* is not available in the explosion-protection version.

